

MCI
Mid-Continent Industries, Inc.
1801 SE 9th ST., PO Box, Newton, KS 67114
316-283-9648* 800-279-6812* Fax 316-283-0745

NEWTON GRAIN CLEANER

PORTABLE

OPERATIONS MANUAL



Newton Grain Cleaner

Operations Manual Table of Contents

	Page
Dimension Sheet.....	1
Assembly Instructions & Suggestions ..(Stationary Model only)..	2
Operation Identification Sheet	3
Operations Explanation	4
Summary of Operation	5
Setting Controls	5
What the Operator Should Know	6
Maintenance Chart	7
Adjusting the Brushes & Screen Hold-Downs	7
Warranty	8
Parts Listing	9
Parts Identification Sheet.....	9a
Approximate Capacities of the Newton Grain Cleaner	10, 11

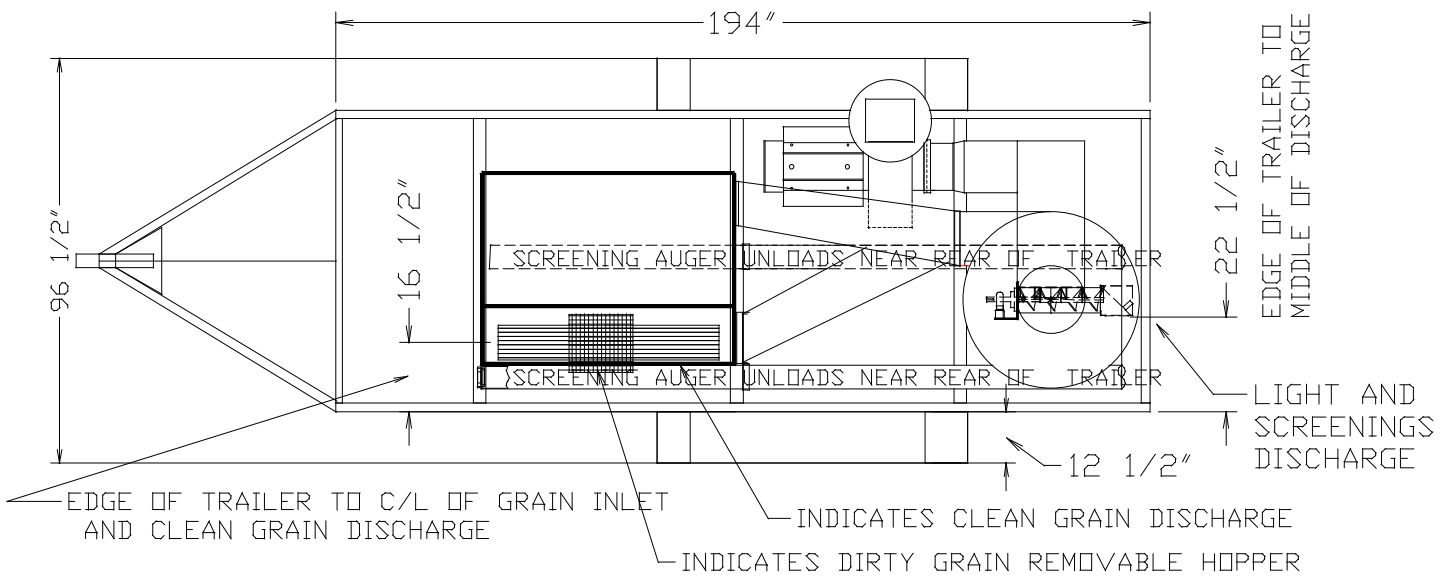
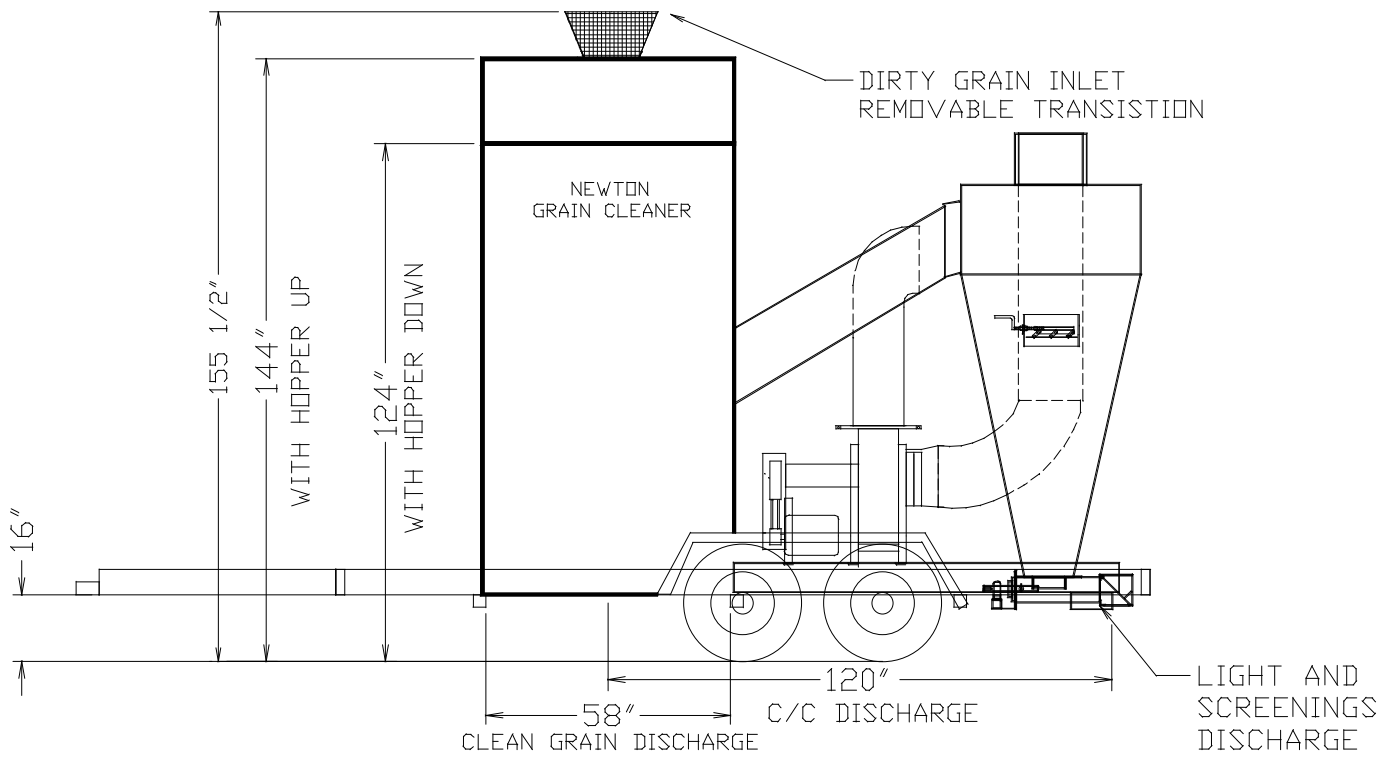

REQUIRES 3 PHASE ELECTRICAL

OPERATION IDENTIFICATION SHEET

NGC/MANUAL/PARTBOK2

FRONT VIEW

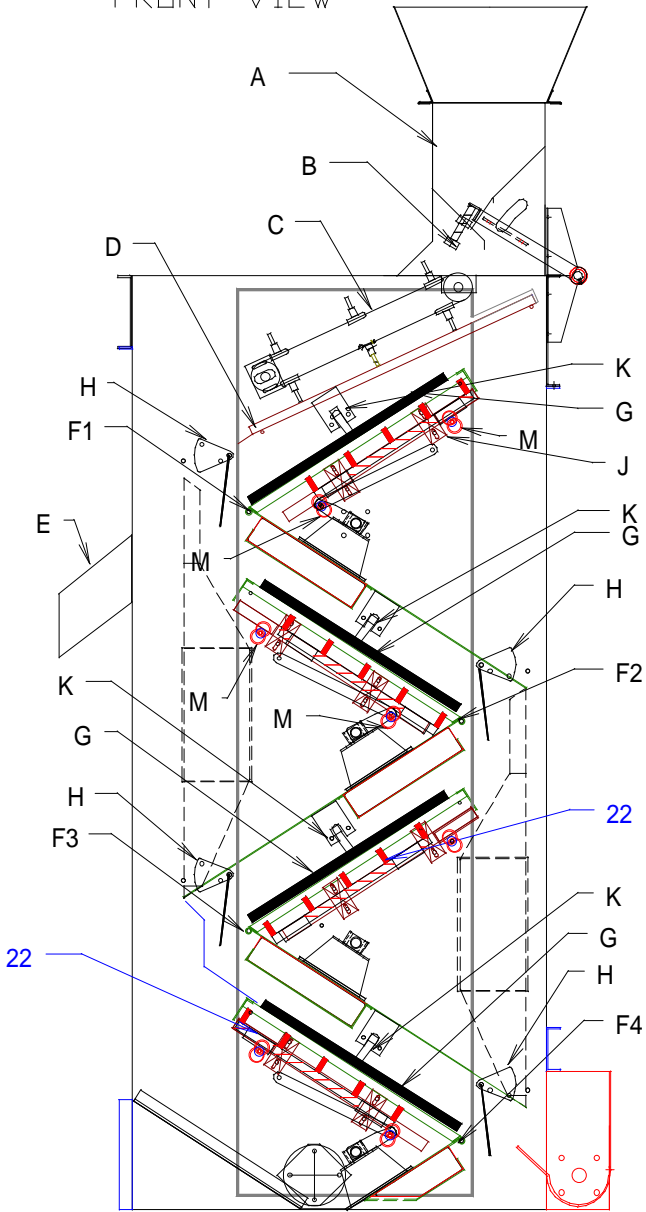

BACK VIEW

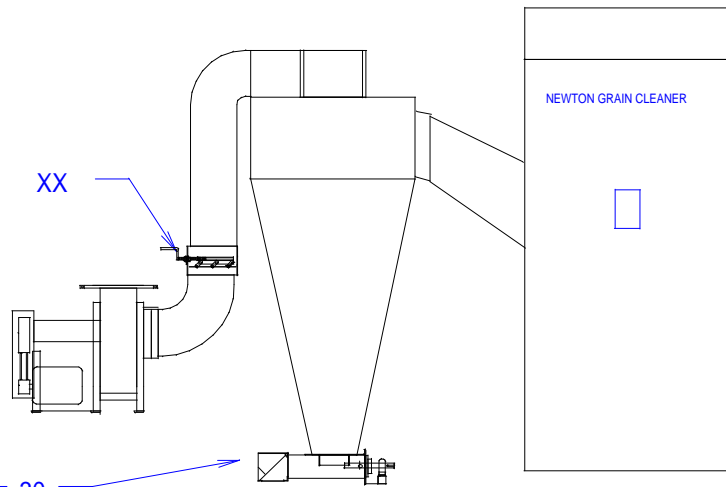
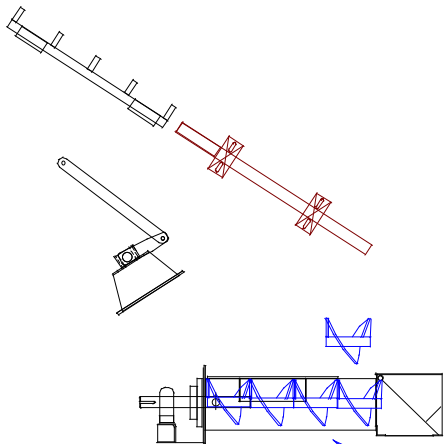
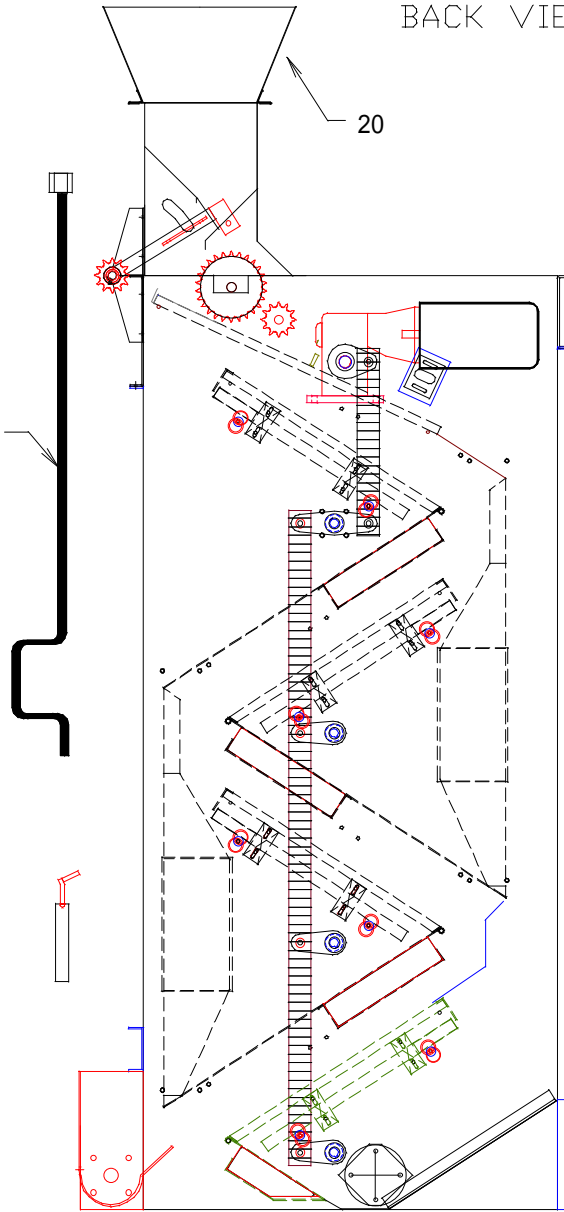

operationid

NEWTON GRAIN CLEANER

Operations

- ◆ Grain is fed in at the top of the spreader hopper **A**. The spreader hopper must be choke fed. *Choke feeding works best when the inlet hopper **20** is used.*
- ◆ Adjusting bolt **B** meters the grain onto the scalp screen **D**.
- ◆ The larger particles are then dragged by **C** across the scalp screen **D**, and are discharged at the scalp discharge spout **E**.
- ◆ The grain and fines drop through the scalp, and begin to slide down screen #1 **F1**.
- ◆ Air is drawn through the falling grain as it drops from screen #1 **F1** to screen #2 **F2**.
- ◆ The fines fall through screen #1 **F1**, and slide down the screening pan to drop to the bottom of the cleaner. The screen is held in place with a screen hold down **G**.
- ◆ As the grain passes off screen #1 **F1**, it will strike grain plate **H**. This grain plate is adjusted to obtain the desired aspiration.
- ◆ The grain then continues down screen #2 **F2** and drops from screen #2 **F2** to screen #3 **F3**.
- ◆ Again, the grain is aspirated. This also happens on screen #3 **F3** and screen #4 **F4**.
- ◆ The grain is then discharged out the bottom of the cleaner.

Various sizes of scalp screens and fine screens are available depending upon how much material is to be removed from the product. The by-product can also be regulated by the amount of flow or speed out of the spreader hopper **A**. Using adjuster wrench **31**, turn adjuster bolt **B** on the spreader hopper clockwise to increase the flow.

The amount of aspirated material removed may be controlled by adjustment of the grain plate **H**. The air damper **XX** on the cyclone regulates the air drawn through the grain. This aspirated material should be monitored at the airlock **30**.

The moving brush racks **22** under each screen aid in keeping the screens clean for maximum removal of fines. However, the quality of some products may require the **F** screens to be removed periodically and manually cleaned. Make sure that the “trash” is not building up under the lower end of the brush rack travel. Too much build up will cause excessive stress on the brush drive mechanism.

Adjustment procedures for the brushes and the screen hold-downs are explained on the maintenance chart, page 7.

NEWTON GRAIN CLEANER

Summary of Operation

The grain flow is adjustable as it enters the cleaner. The large parts are scalped off and the grain falls onto and cascades down the screens. The screens are kept clean (open) by brushes while the grain plate and the air damper regulate the air. The aspirated material is monitored at airlock auger **30**. Fines, or screenings, are monitored at their auger discharge and the clean grain must be monitored to obtain the desired results.

Setting Controls

Most grains react similarly in the Newton Grain Cleaner. Corn, wheat, milo, soybeans, barley and similar grains are included in this section. Spreader hopper **A** will normally be set more open with coarse grains, between 1 1/2" and 4" open, and between 1/2" and 2 1/2" with small grains. The opening of spreader hopper **A** controls how much grain is cleaned in a specific period. Screen sizes and the feed hopper opening affect screening volumes. The aspirated material amounts also vary according to the settings of the feed hopper opening.

Grain plates **H** must be set so there is a "boil" of grain as it strikes the grain plate.

- ◆ With the door open, loosen the wing nut holding **H** and move **H** back and forth to obtain an obvious striking of the grain against the grain plate (boil). This adjustment will place the grain plate approximately 1 1/2" from the edge of the screens **F1** through **F4**. The grain plates may also be used to control the speed of the grain running across the screen.
- ◆ The air damper **XX** may be changed to adjust the volume of air being drawn through the grain. Airlock **30** should emit dust and light particles and small, cracked grain. For maximum efficiency, a few kernels of whole grain should be found in the aspirated materials.

Recommended screen sizes are listed on page 10 in the approximate capacities section. *If the desired screen size is not found, please call Mid-Continent Industries, as other sizes may be available.* Flow and screen size determines removal through the screens, which may be mixed, matched, or replaced by blanks. Adjustments for brushes and screen hold-downs are explained on the maintenance chart, page 7.

- ◆ **F1** screens remove approximately 40% of by-products on screen # 1
- ◆ **F2** screens remove approximately 30% of by-products on screen # 2
- ◆ **F3** screens remove approximately 20% of by-products on screen # 3
- ◆ **F4** screens remove approximately 10% of by-products on screen # 4

sumoper

NEWTON GRAIN CLEANER

Operator Requirements

The Newton Grain Cleaner **MUST** be operated with all shields and guards in place.

Proper start-up procedure of the grain cleaner

1. Start the augers
 2. Start the cleaner cabinet
 3. Start the aspirating fan
 4. Start **all** other conveying equipment before starting the grain flow
 5. Begin grain flow with the air damper almost closed. Adjust air damper opening as the grain flow increases to obtain desired results.
 6. Check your aspirated lifting for excessive whole grain. Reduce airflow if too much whole grain is present.
- ◆ Grain plates **MUST** be set to obtain a “boil” of the grain against the grain plate.
 - ◆ The spreader feed hopper should be set for maximum flow to obtain desired results.
 - ◆ Screen size is a matter of choosing the proper screens to achieve the desired results.

When shutting the Newton Grain Cleaner down, the fan must be COMPLETELY stopped before turning off the augers and the grain cleaner cabinet. Failure to do so could result in the dust collector bridging.

Do not raise the airlock door during operation as dust and particles will be pulled through the fan. The airlock door should only be weighted heavy enough to create a reasonable seal on the grain. Too much weight on the door will accelerate the wear on the airlock auger. For optimum results check aspirated materials at the airlock approximately every 15 to 30 minutes to ensure proper and efficient operation.

Check the internal cleaner parts daily at start-up to ensure proper mechanism operation. The brushes should be adjusted only tight enough against the screen to obtain maximum cleaning of the screen. Adjusting brushes too tightly results in abnormal wear throughout the brush drive mechanism. On some grains, particularly wheat, removing the screens will occasionally be necessary, to clean them by hand if inadequate removal of fines is noticed.

Screening and aspirated material by-products, when mixed for best handling, offer good food value for growing livestock. The mix of the by-product will flow comparable to light oats in most grain handling equipment. Elevators with dust collection systems will avoid losing the dust and light material by-products by reducing air to the equipment.

NEWTON GRAIN CLEANER

MAINTENANCE

Lube:	Airlock Bearings	300 hours
	Feeder Bearings	300 hours
	Scalp Bearings	300 hours

The above bearings are sealed on units built after serial #038904.

Check:	Gearboxes	100 hours or if leaks appear
	Change Oil	After first 25 hours & Every 600 hours thereafter

Replace lube with a high quality SAE 80W90 or equivalent gear lube.

Roller Chain: Roller chain tension on drag scalps should be snug.
Roller chain on feed rollers should have slack.

Check:	Bolts	After first 10 hours
---------------	-------	----------------------

Check all cleaner bolts, inside and outside, for proper tightness, particularly brush operations.

ADJUSTMENTS

Make sure there is no build up on the back screen rack when adjusting either screen hold-downs or brushes.

Screen hold-downs

1. Open the door on the front of the cleaner cabinet.
2. Adjust the screen hold-down **G** before adjusting the brushes by loosening the **K** bolts
3. Move hold-downs firmly against the screens using tool **32**.

Brushes

1. Find the screen holder bolts **J**.
2. Loosen three of the four bolts.
3. On the bracket, where both bolts **J** are now loose, squeeze the brush guide toward the screen until the brush touches the screen firmly without protruding though.
4. Tighten **ONE** bolt on that bracket
5. Loosen the bolt on the other bracket that was not previously loosened and repeat the brush adjustment process on that bracket.
6. Tighten all four bolts.
7. Locate the eccentric adjuster **M** inside the cleaner cabinet on the back wall.
8. Have an assistant go around to the back of the cleaner cabinet and locate the screen holder bolts (remember the bolt pattern from the front). The assistant must repeat the loosening and tightening sequence of these bolts performed on the front, communicating each step with the person in front.
9. Using the adjuster wrench **31** from the front and turn the adjuster eccentric **M** just enough to squeeze the brush against the screen. **Do not squeeze the brushes against the screen too tightly.** The screen will spring up between the hold-down bars, causing a reduction in screen cleaning.

maintenance

NEWTON GRAIN CLEANER

*** Limited Warranty ***

Mid-Continent Industries, Inc., hereafter known as MCI, does warrant to the original purchaser, the Newton Grain Cleaner, against defective materials and workmanship, from the date of delivery, with the exception of the following components and chassis.

Two Year Coverage

- FRAME: ALL PARTS
- ALL ELECTRICAL WIRING AND SWITCHES
- MATERIAL PARTS ONLY

NOTE: Motor(s) and fan(s) are covered under specific manufacturer warranties, and are available upon request.

MCI will at its option, repair or replace the defective part(s). All warranty claims **MUST** be made directly to MCI and any warranty parts must be returned to MCI for credit.

MCI will **not** be held liable for any field modifications not expressly furnished and authorized in writing by the engineering department of MCI. Any unauthorized modifications immediately render this warranty null and void. This warranty expires completely fifteen (15) days after of delivery of the unit to the purchaser.

MCI will not be held liable for any consequential damages, nor for commercial consequential damages resulting from any breach of this warranty, or any other warranty. All of which are expressly disclaimed for any delays in performance of this warranty due to causes beyond the direct control of the manufacturer.

MCI neither assumes nor authorizes any person to create nor assume for MCI, any obligation(s) or liability(ies) in connection with MCI products, nor to undertake any responsibilities beyond those set forth in this instrument.

This warranty disclaims any liability whatsoever due to: loss of time, use of the product, anticipated profits, increased expenses or loss of operations by reason of plant shutdowns, inconveniences or any other matter(s) not specified in this warranty.

These warranties are in lieu of any other warranties, expressed or implied, including the extent that any such limitation will be limited by any state of federal law, then such portions of the limitation will be deemed null and void.

Any dispute concerning this warranty will be governed by the laws of the State of Kansas and venue will reside in the State of Kansas.

warranty

NEWTON GRAIN CLEANER

PARTS LISTING

<u>ITEM</u>	<u>DESCRIPTION</u>	<u>PART NUMBER</u>
1	Drag Chain, Complete with Brushes	31B
1	Drag Chain, Less Brushes, Brush	161A
2	Scalp Screen	Order Size
3	Fines Screen	Order Size
4	Hold Down Bars	77A
5	Shoulder Bolt, 3/8 x 1 1/4	1-25943
6	UHMW Push Rods	66A
7	UHMW Crank Bearing (Two Halves)	35A
8	Crankshaft & Arms (2)	64A-65A
9	Shoulder Bolt, 3/8 x 1	1-25942
10	Crankarm Gearbox Inc. 25930	30A
11	UHMW Connecting Bar (Short)	21A
12	Double Rock-Arm Cr. Inc. 25091, 25096	26A
13	UHMW Operating Bar (Long)	20B
14	Single Rock-Arm Cr. Inc. 25091, 25096	27A-28A
15	Single Rock-Arm Cr. Inc. 25091, 25096	27A-28A
16	Bushing, UHMW Drive	25A
17	1" Bore Slip Clutch #50 Complete Sprocket	1-25977
17	Slip Clutch 24 Tooth #50 Replace Sprocket	1-25896
18	UHMW Brush Rack Guide (4)	73A
19	Brush Rack Guide (2)	217, 218A
20	Inlet Grain Hopper	100C
21	5021TTH Double Sprocket w/Assembly 1-25899	1-25898
22	Brush Rack w/o Brushes, Brush	209D
23	Brush Rack Brushes, each 55 3/4 long	2-26015
24	Spread Feed Hopper	165D
25	W55 6TH. Sprocket w/Assembly 1-25987 (2)	1-25979
26	6" Plastic Auger Airlock	2-26155
27	Idler. 5015 1/2 Bore	1-25974
28	Gear Box 40-1 Ratio, Cabinet Operating	2-26170
29	Motor, Cabinet, 1 1/2 HP 145T 1725RPM	2-26220
30	Airlock, Portable, including Auger	263B
30	Airlock, Stationary, including AG, GRBS, MTR	269C
31	Speed Handle	193B
32	Hold-Down Tool	196B
33	Screenings Auger Gearbox	2-26192
34	Screenings Auger Drive Motor	2-26218

partlist

APPROXIMATE CAPACITIES OF THE NEWTON GRAIN CLEANER

<u>MODEL</u>	<u>GRAIN</u>	<u>APPROX. BU/HR</u> <u>WITH AIR</u>	<u>APPROXIMATE</u> <u>METRIC TONS/HR</u> <u>WITH AIR</u>	<u>(SUGGESTED)</u> <u>CLEANING</u> <u>SCREENS</u>	<u>(SUGGESTED)</u> <u>SCALPING</u> <u>SCREEN</u>
#7	Wheat	1,000-4,000	25-100	4 or 5/64 slot	1/2 square
	Corn	2,000-6,000	50-150	12/64 or 16/64 sq	5/8 square
	Milo	1,000-6,000	25-150	4 or 5/64 slot	1/2 square
	Beans	2,000-6,000	50-150	12/64 or 16/64 sq	1/2 square
#9	Wheat	1,000-4,000	25-100	4 or 5/64 slot	1/2 square
	Corn	2,000-6,000	50-150	12/64 or 16/64 sq	5/8 square
	Milo	1,000-6,000	25-150	4 or 5/64 slot	1/2 square
	Beans	2,000-6,000	50-150	12/64 or 16/64 sq	5/8 square
#10	Wheat	1,500-5,000	37.5-125	4 or 5/64 slot	5/8 square
	Corn	3,000-9,500	75-237	12/64 or 16/64 sq	3/4 square
	Milo	1,500-9,500	37.5-237	4 or 5/64 slot	5/8 square
	Beans	3,000-9,500	75-237	12/64 or 16/64 sq	3/4 square
#20	Wheat	3,000-10,000	75-250	4 or 5/64 slot	5/8 square
	Corn	6,000-19,000	150-475	12/64 or 16/64 sq	3/4 square
	Milo	3,000-19,000	75-475	4 or 5/64 slot	5/8 square
	Beans	6,000-19,000	150-475	12/64 or 16/64 sq	3/4 square

EMPTY WEIGHT LOADED WEIGHT

STATIONARY	BS	7	2000	6000
STATIONARY	BS	9	2200	8900
STATIONARY	BS	10	2500	10700
STATIONARY	BS	20	5000	19400
STATIONARY	BAS	7	3300	7300
STATIONARY	BAS	9	3500	9100
STATIONARY	BAS	10	3700	10900
STATIONARY	BAS	20	7400	21800
PORTABLE	9	BAS	6300	11900
PORTABLE	10	BAS	6500	13700

SCREENS AVAILABLE

3 1/2/64 X 1 SLOT	6/64 SQUARE	FOR SCALPING
4/64 X 1 SLOT	7/64 SQUARE	3/8 SQUARE
5/64 X 1 SLOT	8/64 SQUARE	7/16 SQUARE
6/64 X 1 SLOT	12/64 SQUARE	1/2 SQUARE
8/64 X 1 SLOT	16/64 SQUARE	9/16 SQUARE
10/64 X 1 SLOT		5/8 SQUARE
12/64 X 2 SLOT		3/4 SQUARE

Actual Sizes for Screens

Scalp 37 x 57 1/2
Fines 30 3/4 x 57 1/2

Actual Screen Cleaning Area

Scalp 56 x 35
Fines 56 x 30

NOTES

- The smaller the opening in the scalp screen the less the capacity.
- Lower capacity figure is **MINIMUM CAPACITY** for **MAXIMUM EFFICIENCY**.
- Other screen sizes may be available. For more information, contact Mid-Continent Industries.

CAPACITY